

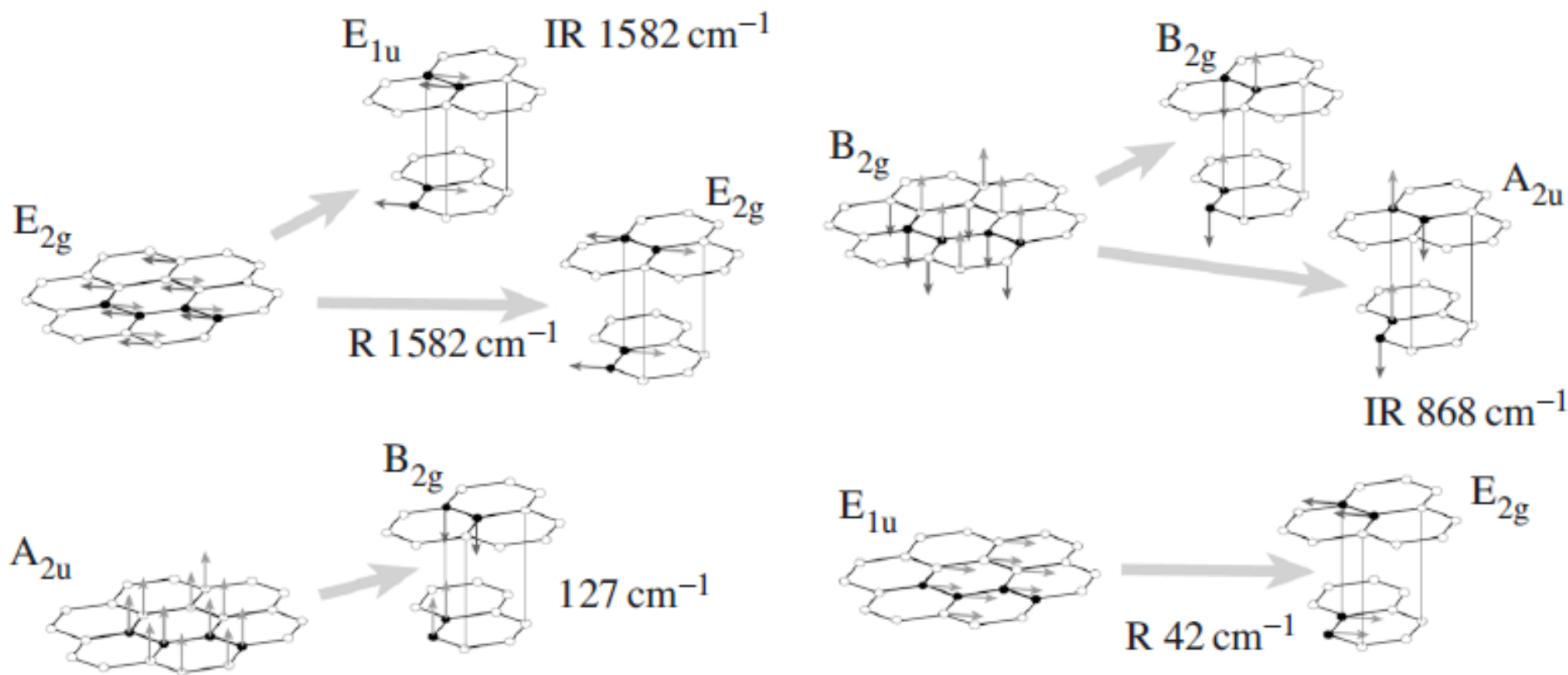

# Vibrations of graphite



## Character table for $D_{6h}$ point group

|                       | E | $2C_6$ | $2C_3$ | $C_2$ | $3C'_2$ | $3C''_2$ | i  | $2S_3$ | $2S_6$ | $\sigma_h$ | $3\sigma_d$ | $3\sigma_v$ | Linear,<br>rotations | Quadratic       |
|-----------------------|---|--------|--------|-------|---------|----------|----|--------|--------|------------|-------------|-------------|----------------------|-----------------|
| <b>A<sub>1g</sub></b> | 1 | 1      | 1      | 1     | 1       | 1        | 1  | 1      | 1      | 1          | 1           | 1           |                      | $x^2+y^2, z^2$  |
| <b>A<sub>2g</sub></b> | 1 | 1      | 1      | 1     | -1      | -1       | 1  | 1      | 1      | 1          | -1          | -1          | $R_z$                |                 |
| <b>B<sub>1g</sub></b> | 1 | -1     | 1      | -1    | 1       | -1       | 1  | -1     | 1      | -1         | 1           | -1          |                      |                 |
| <b>B<sub>2g</sub></b> | 1 | -1     | 1      | -1    | -1      | 1        | 1  | -1     | 1      | -1         | -1          | 1           |                      |                 |
| <b>E<sub>1g</sub></b> | 2 | 1      | -1     | -2    | 0       | 0        | 2  | 1      | -1     | -2         | 0           | 0           | $(R_x, R_y)$         | $(xz, yz)$      |
| <b>E<sub>2g</sub></b> | 2 | -1     | -1     | 2     | 0       | 0        | 2  | -1     | -1     | 2          | 0           | 0           |                      | $(x^2-y^2, xy)$ |
| <b>A<sub>1u</sub></b> | 1 | 1      | 1      | 1     | 1       | 1        | -1 | -1     | -1     | -1         | -1          | -1          |                      |                 |
| <b>A<sub>2u</sub></b> | 1 | 1      | 1      | 1     | -1      | -1       | -1 | -1     | -1     | -1         | 1           | 1           | $z$                  |                 |
| <b>B<sub>1u</sub></b> | 1 | -1     | 1      | -1    | 1       | -1       | -1 | 1      | -1     | 1          | -1          | 1           |                      |                 |
| <b>B<sub>2u</sub></b> | 1 | -1     | 1      | -1    | -1      | 1        | -1 | 1      | -1     | 1          | 1           | -1          |                      |                 |
| <b>E<sub>1u</sub></b> | 2 | 1      | -1     | -2    | 0       | 0        | -2 | -1     | 1      | 2          | 0           | 0           | $(x, y)$             |                 |
| <b>E<sub>2u</sub></b> | 2 | -1     | -1     | 2     | 0       | 0        | -2 | 1      | 1      | -2         | 0           | 0           |                      |                 |

|  |  |  |  |  |  |  |  |  |  |  |  |  |  |  |
|--|--|--|--|--|--|--|--|--|--|--|--|--|--|--|
|  |  |  |  |  |  |  |  |  |  |  |  |  |  |  |
|  |  |  |  |  |  |  |  |  |  |  |  |  |  |  |

ment.

# Photonic crystal

- Band structure for photons from translational symmetry

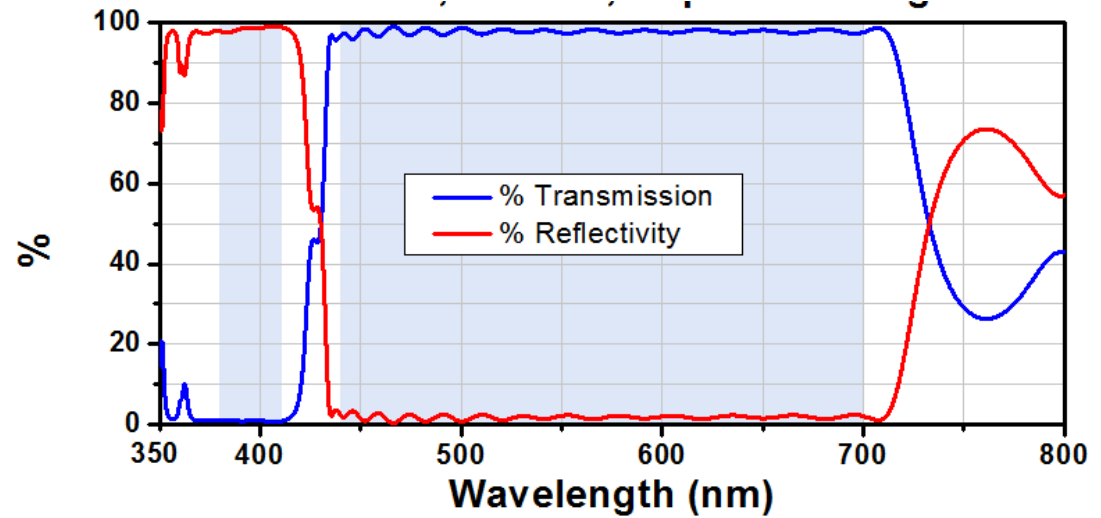
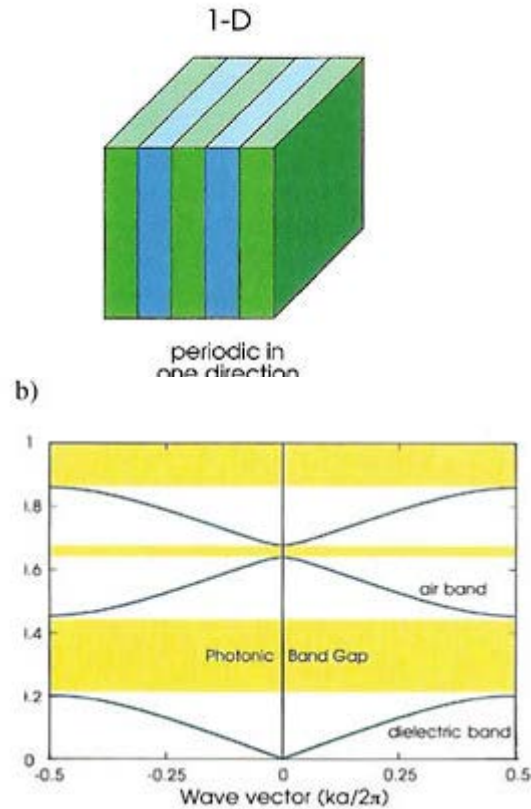

# Photonic crystal

- Band structure for photons from translational symmetry

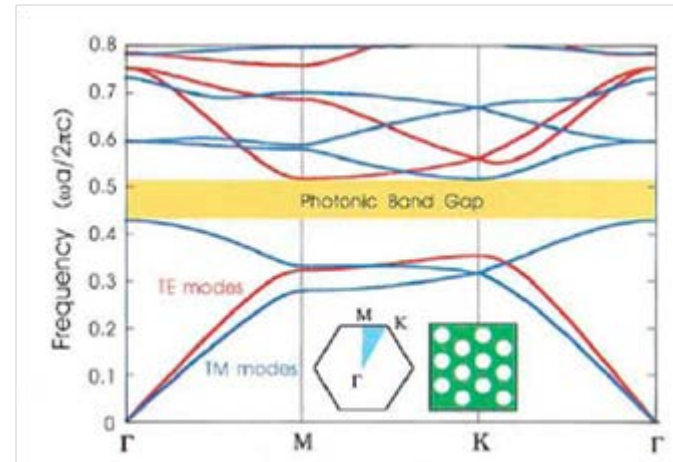
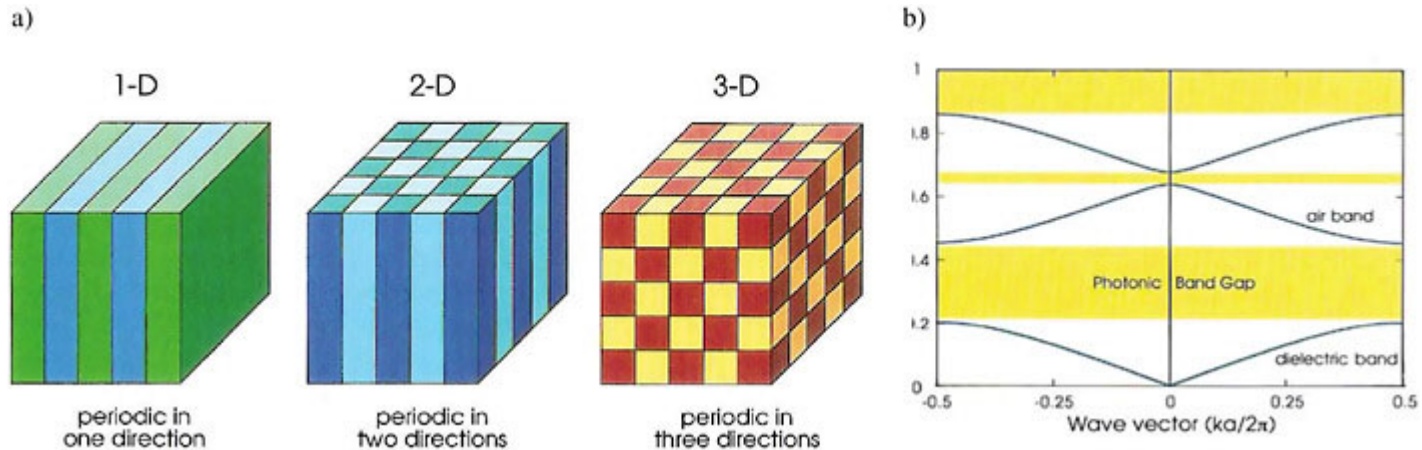

Key player: Joannopoulos (MIT, 90th first concepts)

# Holographic 3D photonic crystal

- Laser wave vectors span reciprocal lattice  $\rightarrow$  pattern in real space

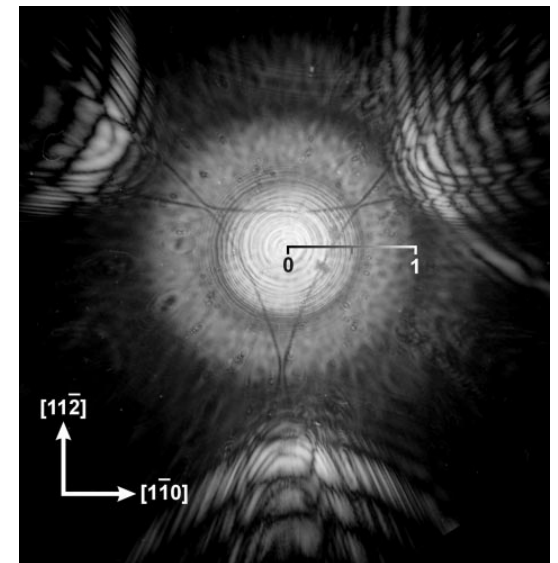
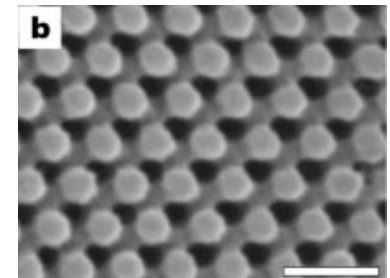
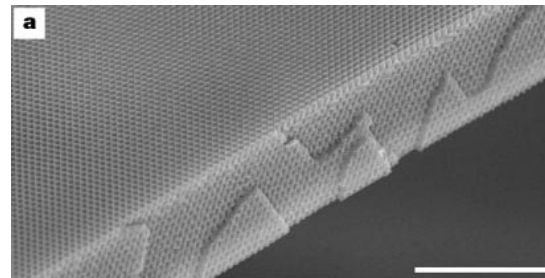
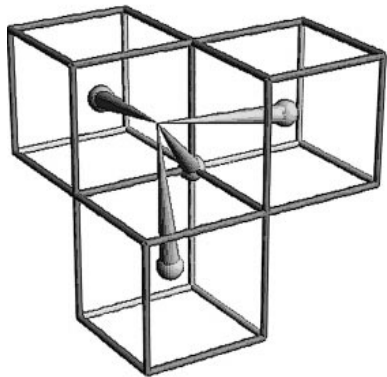
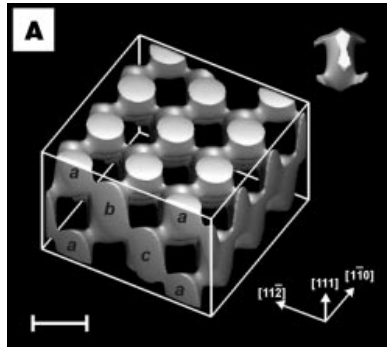

# Holographic 3D photonic crystal

- Laser wave vectors span reciprocal lattice  $\rightarrow$  pattern in real space

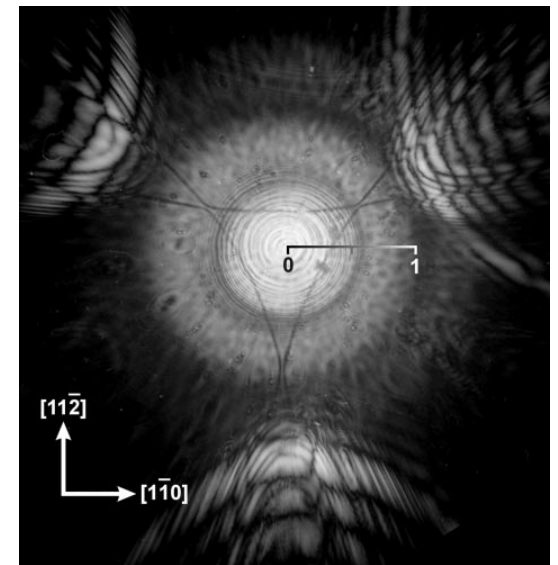
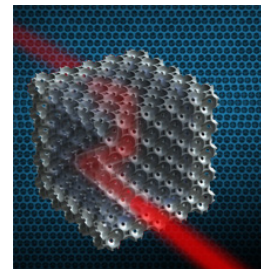
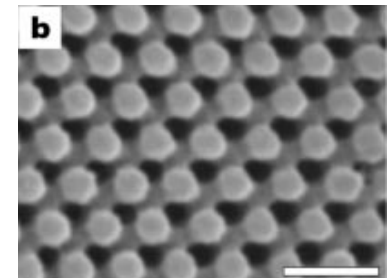
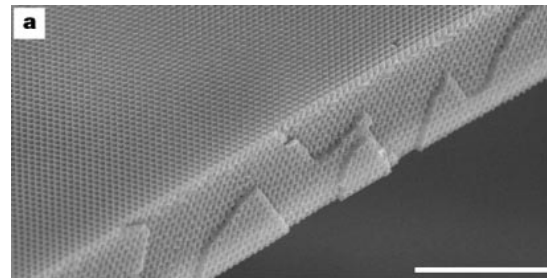
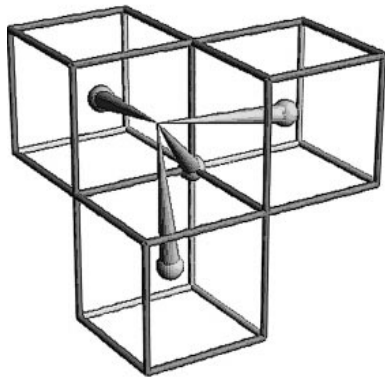
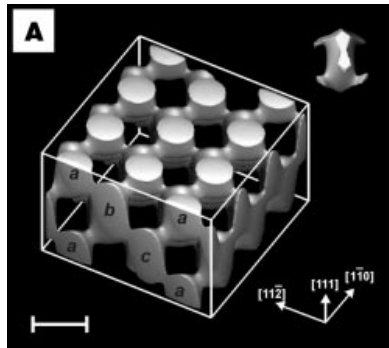

# Wave guide

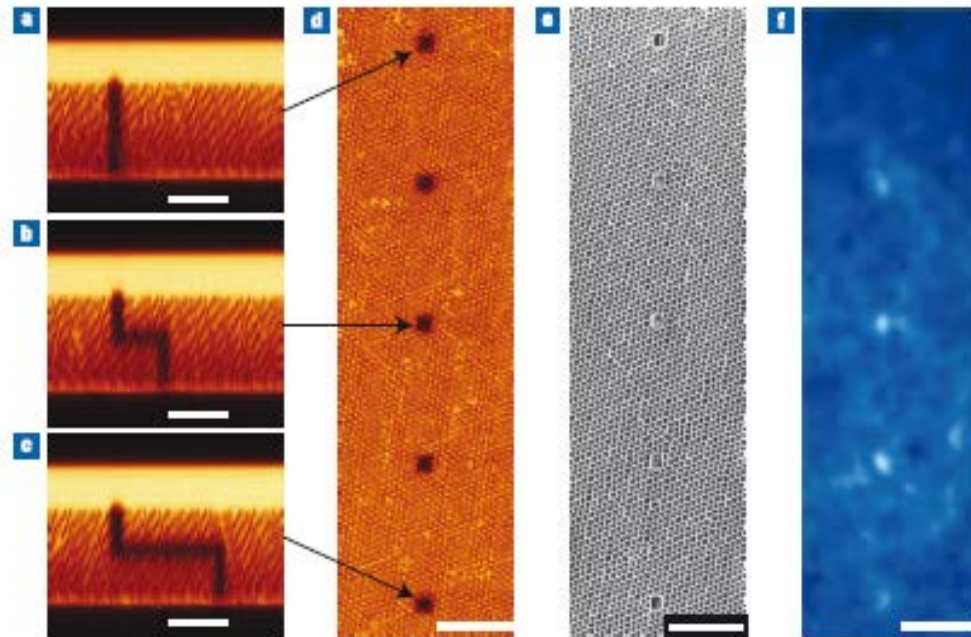
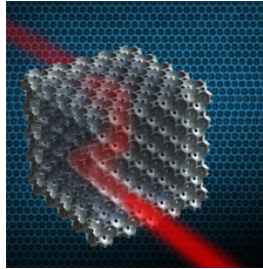



# Phononic crystals

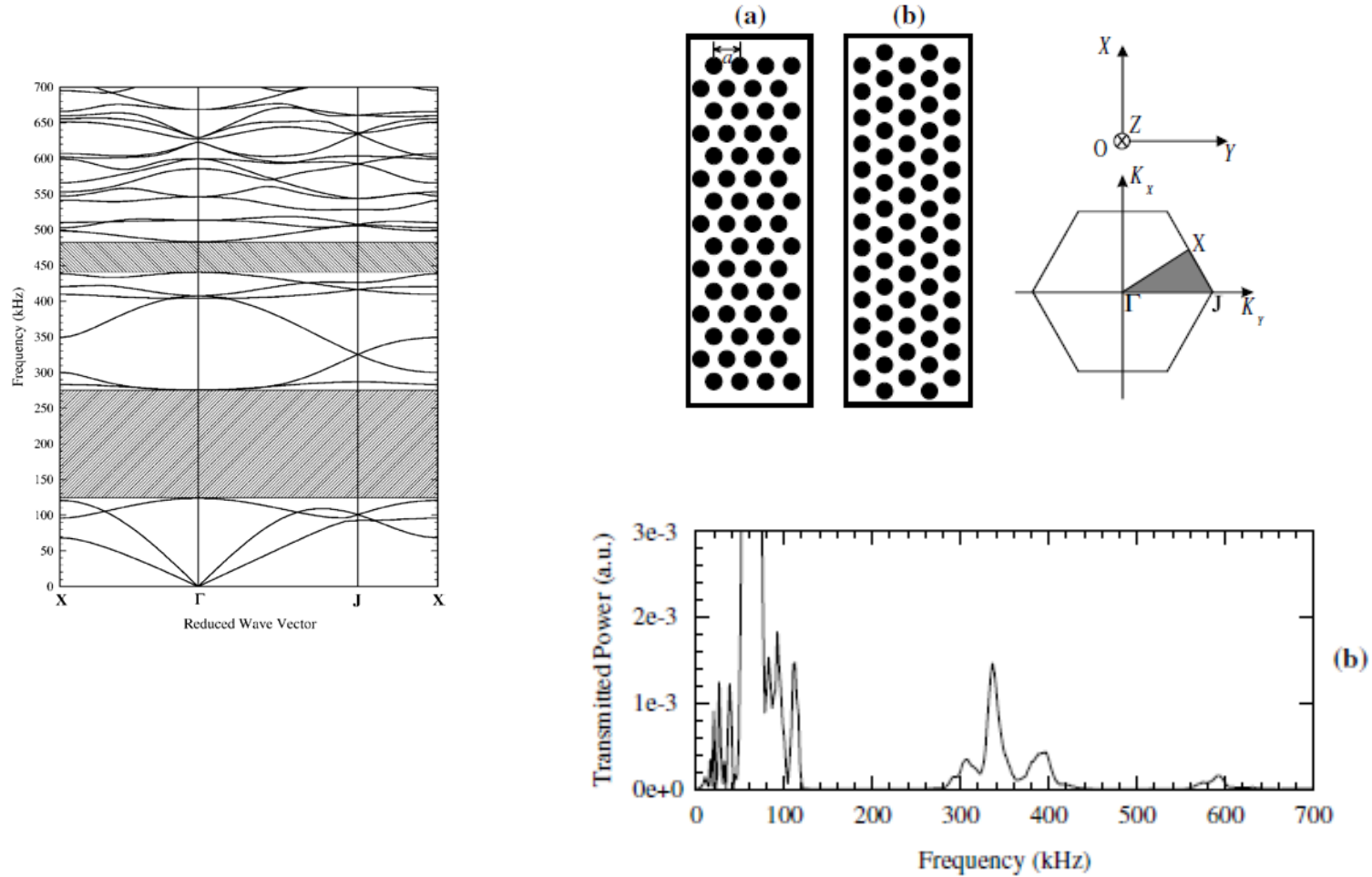

Vasseur, Phys. Rev. Lett. (2001).

# Keep going!

- Optomechanical crystals & circuits

